



## Model Number

**NBN25-30GM50-UO-V93**

## Features

- Cylindrical
- 25 mm non-flush
- 2-wire AC/DC

## Technical Data

### General specifications

Switching function	Normally closed (NC)
Output type	Two-wire
Rated operating distance	$s_n$ 25 mm
Installation	non-flush
Output polarity	AC/DC
Reduction factor $r_{Al}$	0.47
Reduction factor $r_{Cu}$	0.44
Reduction factor $r_{304}$	0.77
Output type	3-wire

### Nominal ratings

Operating voltage	$U_B$	20 ... 250 V AC/20 ... 300 V DC
Switching frequency	$f$	30 Hz
Hysteresis	$H$	3 ... 15 typ. 5 %
Reverse polarity protection		yes
Short-circuit protection		yes
Voltage drop	$U_d$	$\leq 8$ V
Operating current	$I_L$	4 ... 500 mA AC/DC
Off-state current	$I_r$	$\leq 0.8$ mA
Operating voltage indicator		LED, green
Switching state indicator		LED, yellow

### Ambient conditions

Ambient temperature	-25 ... 70 °C (-13 ... 158 °F)
Storage temperature	-40 ... 85 °C (-40 ... 185 °F)

### Mechanical specifications

Connection type	Connector 7/8 inch-16 UN , 3-pin
Housing material	brass, nickel-plated
Sensing face	PBT
Degree of protection	IP67

### Compliance with standards and directives

Standard conformity	
Standards	EN 60947-5-2:2007 EN 60947-5-2/A1:2012 IEC 60947-5-2:2007 IEC 60947-5-2 AMD 1:2012

### Approvals and certificates

UL approval	cULus Listed, General Purpose
CSA approval	cCSAus Listed, General Purpose
CCC approval	Certified by China Compulsory Certification (CCC)

## Dimensions

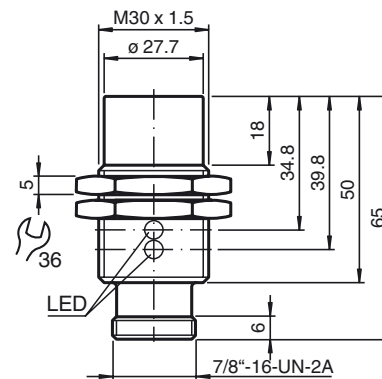

## Electrical Connection

